

GLOBOIDAL INDEXING AND OSCILLATING DRIVES

65G•80G•105G•130G•165G•200G•250G

CF4



- Cuboid shaped; super strong; cast iron housing.
- Machined outer faces with mounting holes to 4 sides.
- Possibility of mounting unit in any plane.
- Input shaft extension dimensions to DIN 748 page 1.
- Indexed output shaft with attachment flange.
- Shafts located in taper roller bearings.
- Lubrication by oil bath or "no maintenance" long life.
- Worm gear reducer directly mounted on housing.



COLOMBO FILIPPETTI SPA
COLLABORATIVE ENGINEERING

CF1401 09-06

Via Rossini, 26 I-24040 CASIRATE D'ADDA -BG -Tel 0363-3251 Fax 0363-325252
<http://www.cofil.it> - E-mail cofil@cofil.it

Contents

PAG

1.	Versions	2
2.	Housed units	3
3.	Assembly position of the gear motor.....	4
4.	Standard gear motors - Overall dimensions	5
5.	Cams for limit switches; types; overall dimensions an positions .	6
6.	Lubrication.....	7
7.	Ordering code.....	8
8.	Assembly position.....	8
9.	Table of dynamic capacities	9

The units of measurement correspond with System International /Severity Index SI General tolerances of manufacture are conform to UNI – ISO 2768-1 UNI EN 22768-1
Illustrations and drawings according to UNI 3970 (ISO 128-82).

Method of projection of the drawings.

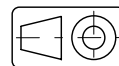

All rights reserved. No part of this catalogue may be duplicated.

COLOMBO FILIPPETTI may make any changes they feel necessary for the improvement of their products without advance notice.

COLOMBO FILIPPETTI may change any market components and accessories mentioned in this catalogue as they feel necessary.

This catalogue supersedes all earlier ones.



VERSIONS

CF4 INDEX DRIVES are normally available in the versions illustrated below. Information on the power drive system and the overall dimensions of the standard gear motors will be supplied on demand.

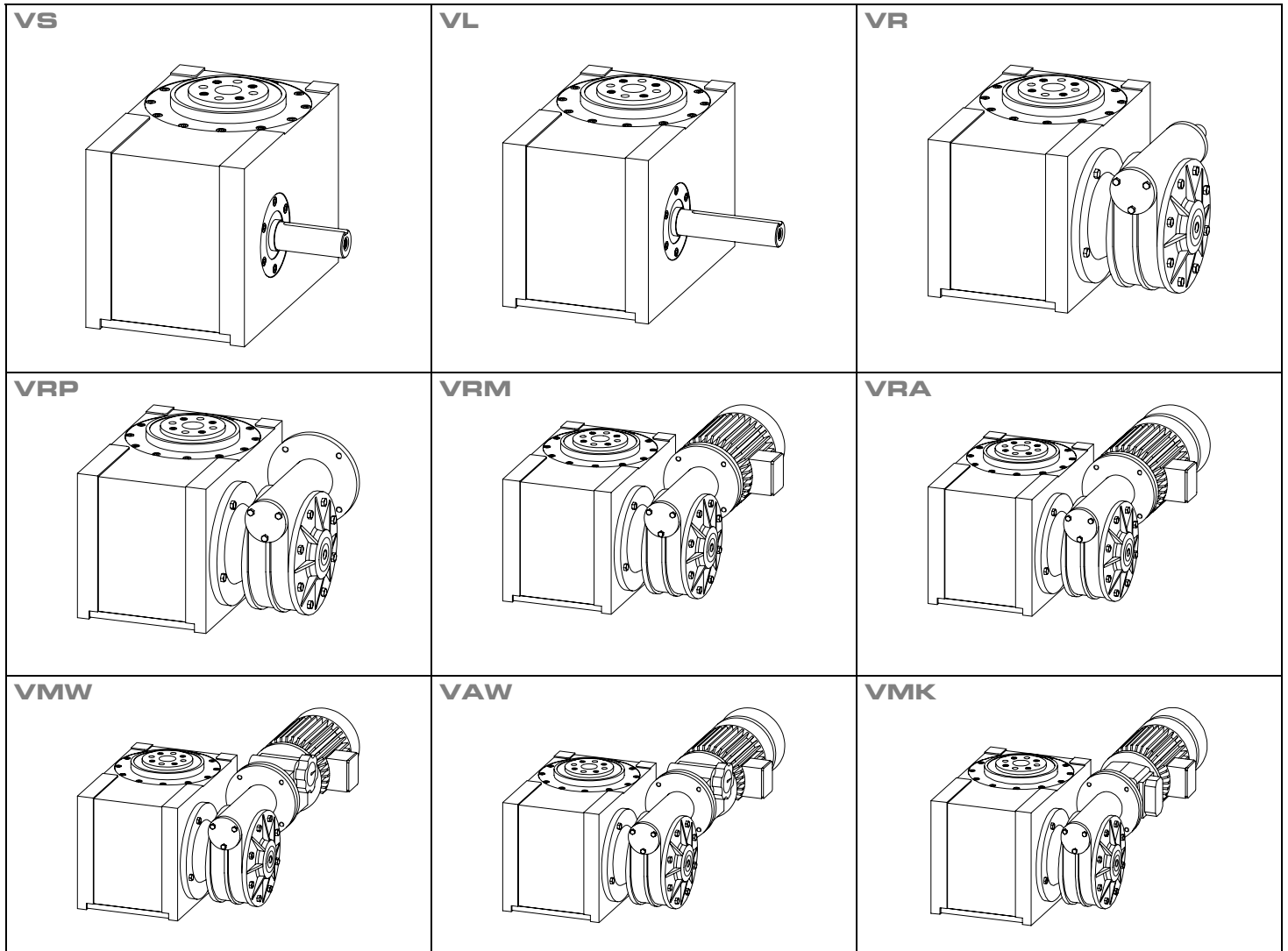
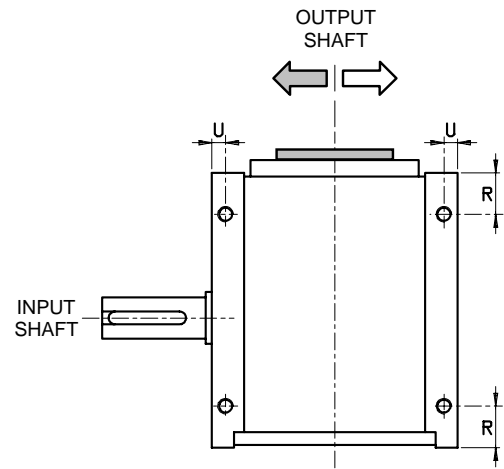
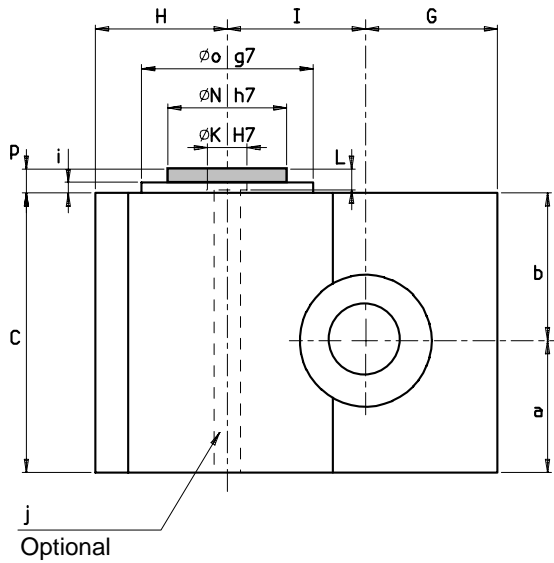

Fig.1 – Versions

- VS** Standard version.
- SS** Special version (box, input shaft, output).
- VL** Version with long shaft preset for reduction gear coupling.
- VR** Version with reduction gear.
- VRP** Version with reduction gear preset for motor coupling.
- VRM** Version with reduction gear and motor.
- VRA** Version with reduction gear and self-braking motor.
- VMW** Version with reduction gear and speed variator.
- VAW** Version with reduction gear and self-braking speed variator.
- VMK** Version with reduction gear, clutch brake and motor.

NOTE: It is possible to have a torque limiter incorporated inside the worm reducer. This type is denoted by placing the letter "L" after the letter "V" eg. VRP would become VLRP.

HOUSED UNITS



NOTES:

- By reversing the direction of rotation of the input shaft, the direction of rotation of the output shaft is reversed while the kinematic characteristics of the intermittent motion are unchanged.
- The slot for the feather key of the input shaft is in the position shown on the figure when the INDEX DRIVE is halfway through its rest period.
- The four holes for "O" plug and the four threads hole "P" are in the position shown on the figure when the INDEX DRIVE is at rest at any of the stations. The dimensions of the "O" holes shown on the table provide for simultaneous boring with the piece to be keyed during the assembly stage.
- The machined surfaces of the box may be bored to a max depth of 15 mm.
- In standard execution, the box is secured by the threaded hole "S" located on the four faces as shown on the drawing.
- On demand, the input shaft may either be provided on the opposite side or, as a special shaft, it may project on both sides.

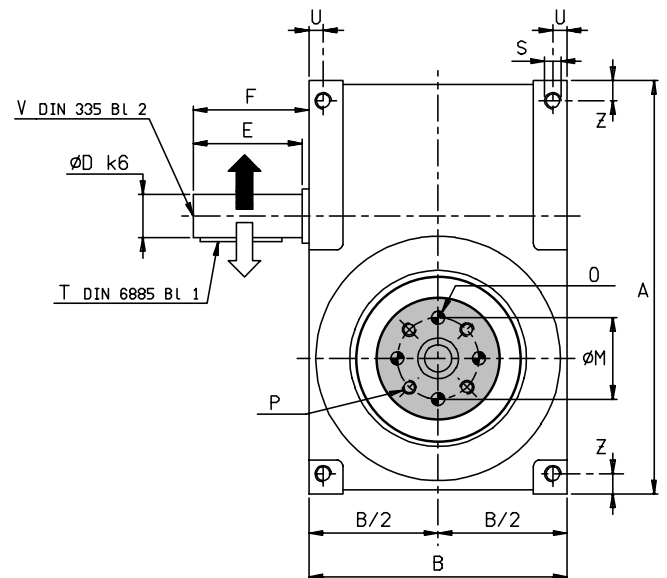

Fig. 2 - Overall dimensions

Series	A	B	C	D	E	F	G	H	I	L	M	N ^{H7}	K ^{H7}	O	P
65G	190	135	130	24	50	55	63	62	65	15	45	65	25	7,5x15	M8x14
80G	235	160	165	28	60	65	80	75	80	15	55	80	30	7,5x15	M8x14
105G	305	190	212	32	80	85	100	100	105	16	60	90	30	9,5x20	M10x20
130G	365	240	237	42	110	115	112	123	130	30	90	120	65	9,5x20	M10x20
165G	465	300	280	48	110	115	150	150	165	30	100	140	80	11,5x20	M12x20

Series	R	S	T	U	V	Z	a	b	i	p	o ^{g7}	j
65G	26	M8x16	8x7x40	9.5	M8x19	12.5	63	67	10	18	95	11
80G	26	M10x16	8x7x55	10.5	M10x22	12.5	80	85	10	18	115	11
105G	32	M10x16	10x8x50	10.5	M12x28	15	100	112	10	18	130	20
130G	32	M14x20	12x8x100	12.5	M16x36	15	112	125	10	20	180	30
165G	42	M16x25	14x9x100	15	M16x36	20	130	150	10	20	210	45

ASSEMBLY POSITION OF THE GEAR MOTOR

CF4 INDEX DRIVES in the versions with standard power drive are fitted with suitably selected worm screw reduction gears which are keyed directly into the input shaft. In the "LCB" version, these reduction gears are supplied with a built-in clutch, so that in case of accidental or emergency stops, overloads caused by dynamic impact are avoided by clutch operation. By mounting this type of drive, the standard execution combines three important elements: safety from shock due to overload during the traversing period stiffness and the compact size of the driver.

The range of reduction ratios available with standard reduction gears makes it possible to obtain set operating speeds within the range of 3 to 200 cycles/min. Other types of power drive, which permit the use of most products currently available on the market, are optional. Please apply to us for information and further details: our Engineering Department will be pleased to advise you on the most suitable drive for your CF4 INDEX DRIVE. Here below, the positions in which the reduction gear or the gear motor may be installed on the CF4 INDEX DRIVE.

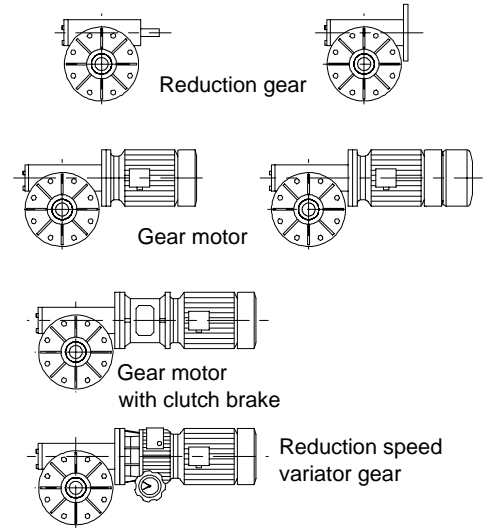

Fig.3: Available drives

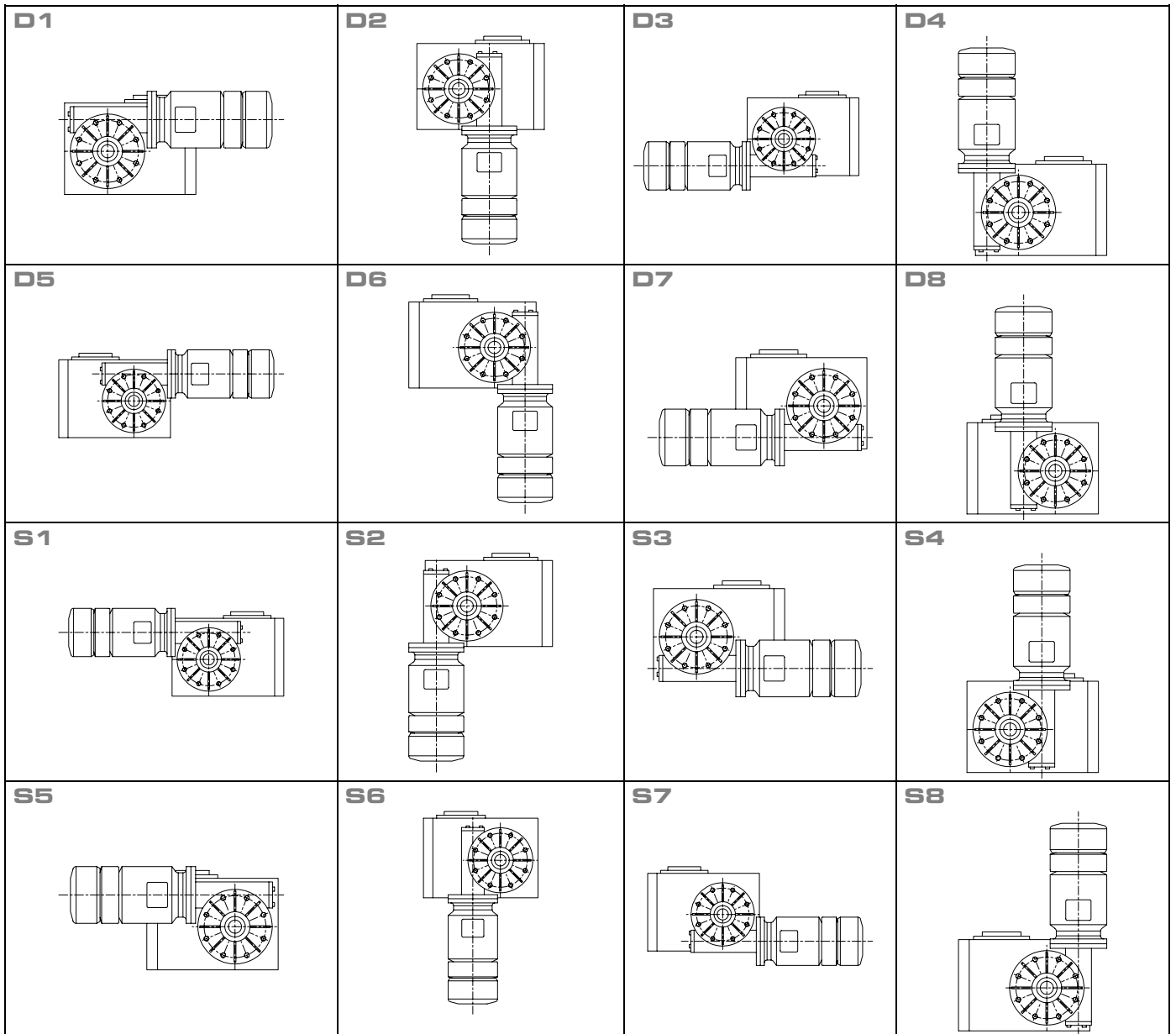

Fig.4: Position of the reduction gear

STANDARD GEAR MOTORS - OVERALL DIMENSIONS

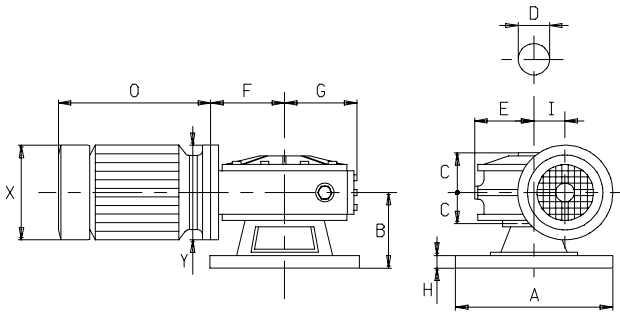

Fig.5 - Reduction gear STM "RMI", flanged version.

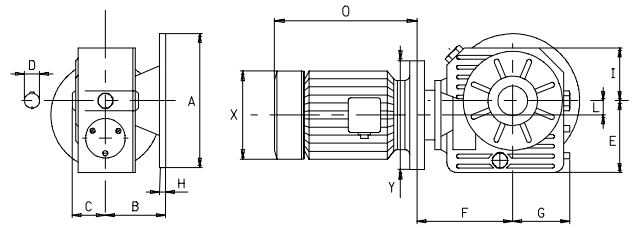

Fig.5a - Reduction gear STM "CBF", flanged version.

NOTE: On demand CF4 INDEX DRIVES may be supplied with motors ©and reduction gears of different types and brands than the standard, or only preset for mounting such.

CF4 SERIES	STM RI RMI	WORM GEAR BOX				4P - 230/400V - 50 Hz Motor					STM CBF	SPUR + WORM GEAR				4P - 230/400V - 50 Hz Motor							
		Overall dim [mm]				Ratios		Self-braking		Overall dim [mm]			Overall dim [mm]		Ratios		Self-braking		Overall dim [mm]				
		A	F	G	H	I.E.C.	CV	O	X	Y		A	F	G	H	I.E.C.	CV	O	X	Y			
65G	28 FL	A	70	F	45	100-80-70	*50a	0,05	135	100	80	-											
		B	49	G	40	56-49	*50a	0,05	135	100	80												
		C	30	H	5	40-28-20	56b	0,12	176	108	120												
	LCB	D	14	I	28	15-10-7	56b	0,12	176	108	120												
		E	35																				
65G	40 F1	A	106	F	64	80-70	56b	0,12	176	108	120	40 F1	A	106	F	108	444-400	*50a	0,05	135	100	80	
		B	69	G	63	56-49	63a	0,18	225	124	140		B	69	G	59	350-200	*50a	0,05	135	100	80	
		C	41	H	9	40-28-20	63b	0,25	225	124	140		C	41	H	9	217-171	56b	0,12	176	108	120	
	LCB	D	19	I	40	15-10-7	63b	0,25	225	124	140		D	19	I	57	135-106	63a	0,18	225	124	140	
		E	59										E	78	L	7	86	63a	0,18	225	124	140	
65G 80G© 105G©	50 F1	A	125	F	77	80-70	63b	0,25	225	124	140	50 F1	A	125	F	134	400	56b	0,12	176	108	120	
		B	93	G	72	56-49-40	71a	0,33	301	141	160		B	93	G	69	350-200	56b	0,12	176	108	120	
		C	49	H	11	18-20-15	71b	0,50	301	141	160		C	49	H	11	217-171	63a	0,18	225	124	140	
	LCB	D	24	I	50	10-7	71b	0,50	301	141	160		D	24	I	69	135-106	63b	0,25	225	124	140	
		E	69										E	97	L	9	86	71a	0,33	301	141	160	
		M	15										M	15									
80G 105G 130G©	70 F3	A	160	F	99	80	71a	0,33	301	141	160	70 F2	A	160	F	165	444-400	63a	0,18	225	124	140	
		B	101	G	92	70-56	71b	0,50	301	141	160		B	101	G	93	350-280	63a	0,18	225	124	140	
		C	60	H	11	49-40	80a	0,75	326	160	200		C	60	H	11	217	63b	0,25	225	124	140	
	LCB	D	28	I	70	28-20-15	80B	1,00	326	160	200		D	28	I	88	171	71a	0,33	301	141	160	
		E	87			10-7	80B	1,00	326	160	200		E	127	L	18	135-106	71b	0,50	301	141	160	
		M	20										M	20									
105G 130G	85 FL	A	200	F	116	80	80a	0,75	326	160	200	85 FL	A	200	F	193	444-400	63b	0,25	225	124	140	
		B	100	G	111	70-56	80B	1,00	326	160	200		B	100	G	116	350	63b	0,25	225	124	140	
		C	61	H	13	49-40	90s	1,50	385	180	200		C	61	H	13	280-217	71b	0,50	301	141	160	
	LCB	D	32	I	85	28-20	90L	2,00	385	180	200		D	32	I	107	171	80a	0,75	326	160	200	
		E	105			15-10	90L	2,00	385	180	200		E	145	L	29	135-106	80b	1,00	326	160	200	
130G 165G	110 F1	A	200	F	145	80	90s	1,50	385	180	200	110 F1	A	200	F	239	444-400	80a	0,75	326	160	200	
		B	115	G	142	70-56	90L	2,00	385	180	200		B	115	G	142	350-280	80b	1,00	326	160	200	
		C	78	H	13	49-40	100a	3,00	420	200	250		C	78	H	13	217-171	90s	1,50	385	180	200	
	LCB	D	42	I	110	28-20	100b	4,00	420	200	250		D	42	I	140	135	90L	2,00	385	180	200	
		E	135			15-10	100b	4,00	420	200	250		E	190	L	43	106	100a	3,00	420	200	258	
130G 165G	130 FL	A	300	F	163	100-80	90L	2,00	385	180	200	-											
		B	150	G	159	70-56	100a	3,00	420	200	250												
		C	90	H	18	49-48	100b	4,00	420	200	250												
		D	48	I	130	28-20	112b	5,50	440	224	250												
		E	150			15-10	112b	5,50	440	224	258												

(*) Standard (not self-braking) motor. LCB = Clutch torque limiter © = Adjustment plate thickness M

CAMS FOR LIMIT SWITCHES; TYPES, OVERALL DIMENSIONS AND POSITIONS

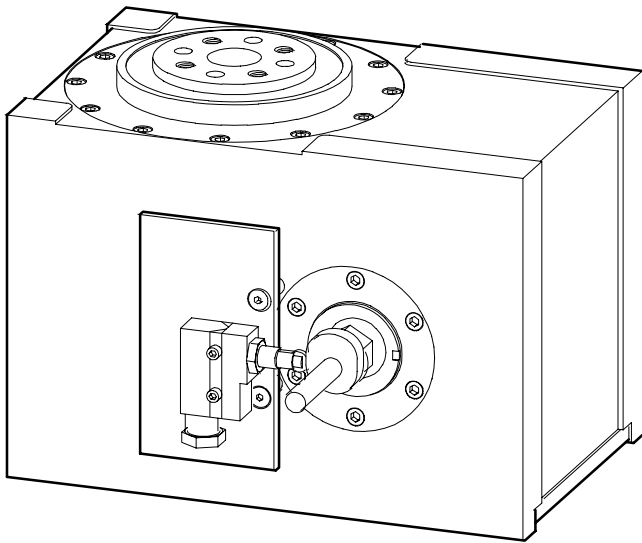

Fig.6

In many applications involving the use of CF4 INDEX DRIVES, the need arises of using a cam-limit switch unit to stop the motor at the end of each cycle.

The stop is required both when the cycle rest period needs extending and when the motor direction of rotation must be reversed, thus producing an oscillating intermittent motion at the output of the CF4 INDEX DRIVE.

The limit switch cams come in three standard shapes, each suitable for the type of limit switch designed to be coupled to it, and are classified as follows:

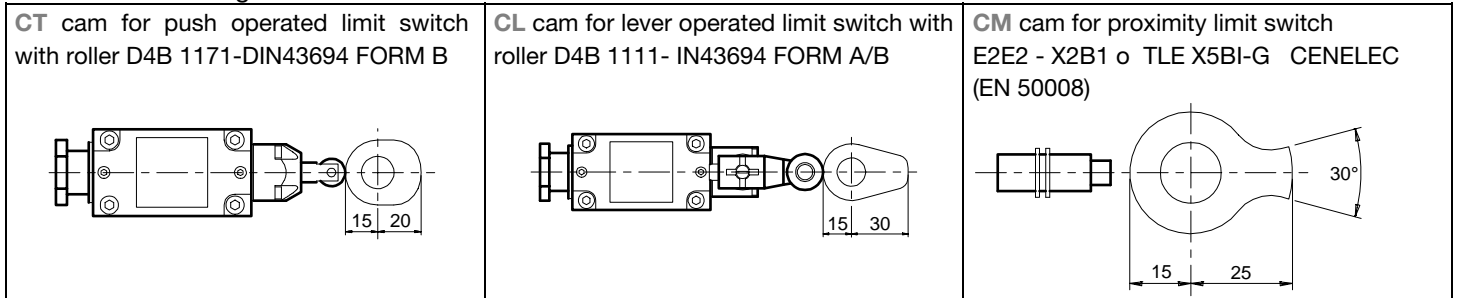

Fig.7

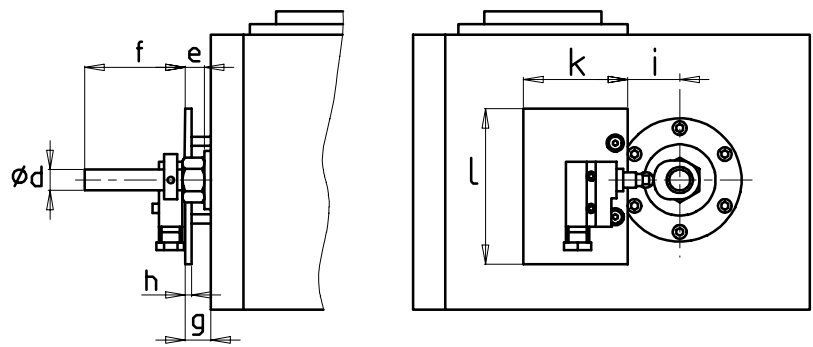

Fig.8

On CF4 INDEX DRIVES the axis of the input shaft key is always half-way through the cam rest period. An indicator notch grooved on the front face of the input shaft marks its position and makes it possible to identify exactly the point where the limit switch should be operated.

An aluminium plate is used as a support for connecting the limit switches, while a pin screwed into head thread of the main shaft serves as a support for the limit switch operating cams.

The limit switch cams are secured to the pin and set in place via flat-tipped dowels.

Series	d	e	f	g	h	i	k	l
65G	16	15	78,5	16,5	5	15	60	80
80G	16	14,5	79	16,5	5	15	60	80
105G	16	14,5	79	16,5	5	15	60	100
130G	16	14,3	82	14	5	15	60	100
165G	16	9,2	82	14	5	30	80	120

LUBRICATION

The shape of the box, the overall machined outer surfaces and the sealed execution make it possible to mount the CF4 INDEX DRIVE in any position. On index drives operating at low speeds (3-50 cycle per minute) and pollution from the outside being absent, long-life lubrication with synthetic grease AGIP GR SLL is provided. On index drives operating at medium speed (40-100 cycle per minute) and pollution from the outside being absent, long-life lubrication with synthetic oil AGIP BLASIA 150S is provided.

CF4 INDEX DRIVES with long-life lubrication are delivered already with the lubrication in the required quantity, and are fitted with a single plugged hole for any topping up that might prove necessary.

On index drives operating at high speeds (90-400 cycle per minute, the lubricant must be changed regularly).

The boxes are fitted oil filling; level and drain plugs, and are delivered without lubricant. It is therefore up to the customer to fill the index drive with the appropriate amount of oil, (as a rule half-way up the level plug), before operating. The lubricant recommended is AGIP BLASIA 150. If no leakage of penetration of foreign matter occurs, the frequency of lubricant change is as shown on Table 5. On index drives operating at even higher speeds, or those that achieve temperatures exceeding those shown on the table, lubricant recirculation with an external cooling system is recommended. The oil plug, when required, are in the positions shown on the picture. For reduction gears, gear motors, variators, etc. lubrication is separate and the rule of the manufacturers of the different items apply.

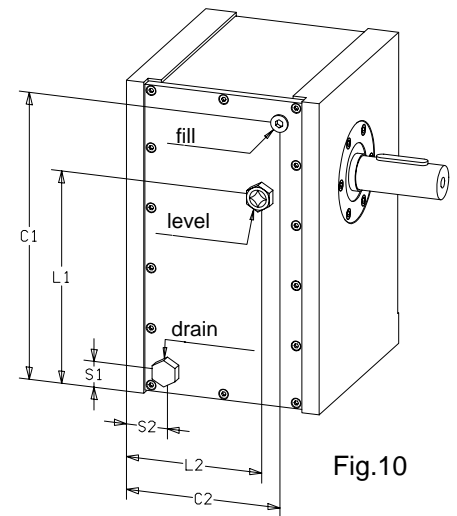

Fig.10

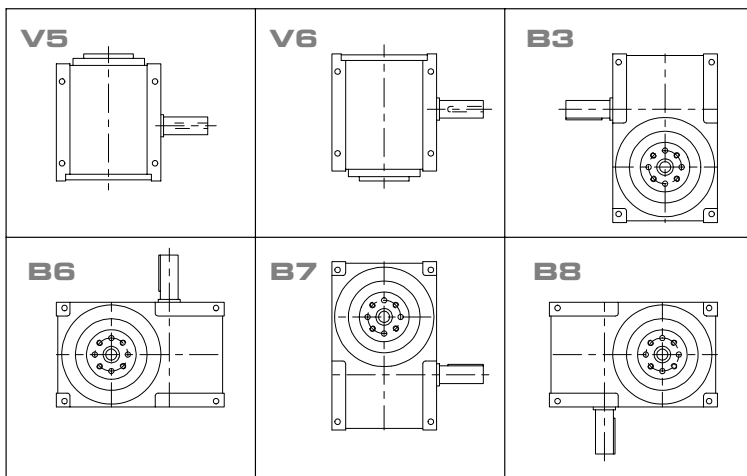

Fig.9

Unless specified otherwise, CF4 index drives are supplied in the standard execution V5 and this code may therefore be omitted when ordering in these cases.

Tab. 4. Indicative amount of lubricating oil in Kg.

CF4 series	V5-B6-V8	V6-B3-B7
65G	1	0,9
80G	3	2,5
105G	4,5	4
130G	10	8
165G	18	14

Table 5 - Frequency of lubrication

Oil temperature [°C]	Frequency of lubrication [h]
< = 65	8,000
65 - 80	4,000
80 -95	2,000

CF4	SERIES				
	65G	80G	105G	130G	165G
C1	168	213	281	340	437
C2	100	120	150	195	228
L1	130	158	208	258	320
L2	82	102	132	177	210
S1	22	22	24	25	28
S2	35	40	40	45	52

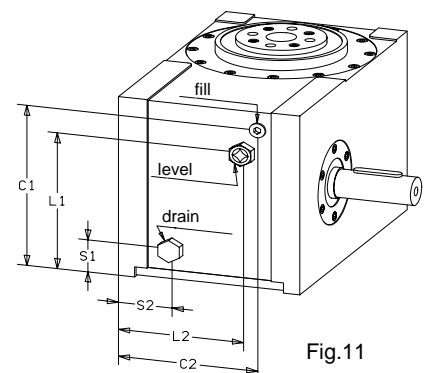

Fig.11

CF4	SERIES				
	65G	80G	105G	130G	165G
C1	96	115	172	192	228
C2	101	120	150	195	248
L1	80	104	135	150	233
L2	90	109	139	180	225
S1	21	22	25	28	52
S2	34	40	40	45	52

ORDERING CODE

The ordering code of CF4 INDEX DRIVES is formed by an alphanumeric combination according to the chart below.

This chart should always be referred to when ordering to avoid misunderstandings, mistakes and delays in delivery.

CF4 INDEX DRIVE

	G				1	2	3	4		
Type										
Number of stations										
Angle of displacement										
Version										
Side with input shaft										
Side of the indexing flange										
Side with securing hole										
Side with oil filling plug (LV long-life lubrication)										
Lower side on assembly										
Mounting position of the reduction gear (do not specify when ordering versions VSS and VSL)										

Limit switch control cam, limit switch and bearings type:

REDUCTION GEAR

Type				
Version				
Reduction ratio				
Built-in torque limiter				

BRAKE CLUTCH

Type Series

MOTOR

Standard or self/braking motor		kW	P	V	/	Hz	V
Size and version							
Power							
No. of poles							
Voltage (V.)							
Frequency							
Brake supply (V.)							

NOTE: List any other possible special power drive characteristics. For the "VRP" version, only indicate the size and version of the motor by marking with a cross the polarity-voltage-frequency boxes.

ASSEMBLY POSITION

	A	B	C	D	E	F
Side with input shaft	<input type="checkbox"/>	<input type="checkbox"/>				
Side of the indexing flange				<input type="checkbox"/>		
Slide with securing holes			<input type="checkbox"/>	<input type="checkbox"/>	<input type="checkbox"/>	<input type="checkbox"/>
Side with oil filling plug			<input type="checkbox"/>		<input type="checkbox"/>	<input type="checkbox"/>
Bottom side on assembly	<input type="checkbox"/>	<input type="checkbox"/>	<input type="checkbox"/>	<input type="checkbox"/>	<input type="checkbox"/>	<input type="checkbox"/>

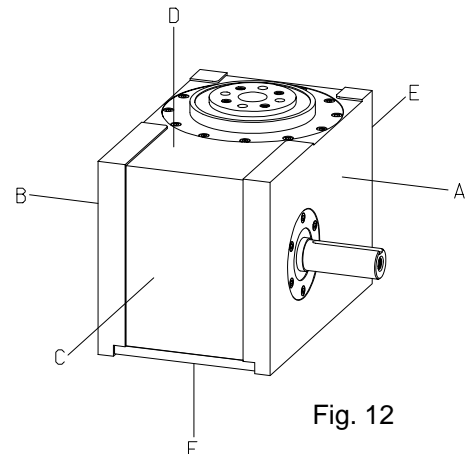

Fig. 12

NOTE: If the designation is incomplete or missing altogether, CF4 INDEX DRIVES are supplied in the "V5" execution and with long-life lubrication with synthetic oil.

65G•80G•105G•
130G•165G

CF4 GLOBOIDAL INDEXING DRIVES

TABLE OF DYNAMIC CAPACITIES

CF4 CODE				Static torque Ms [da Nm]	Dynamic torque (at output) cycle/min					Coeff. of velocity Cv	Coeff. of Accel. Ca	Coeff. of Transm. kJ-KI						
Series	Number of stations S	Angle of displacement B°	Angle of dwell Bp°		50 cycles/1'	100 cycles/1'	150 cycles/1'	200 cycles/1'	300 cycles/1'									
CF4 65 G CF4 80 G CF4 105 G CF4 130 G CF4 165 G	1	330	30	7,0 15,5 27,0 54,0 98,0	5,5 11,5 23,0 37,0 77,0	5,3 10,7 20,7 30,3 54,2	5,0 9,8 19,0 27,6 49,4	4,7 9,1 17,6 25,7 46,1	3,9 7,7 14,8 21,6 38,7	1.27	8.01	0.78-1.39						
CF4 65 G CF4 80 G CF4 105 G CF4 130 G CF4 165 G	2	180	180	7,0 15,5 27,0 54,0 98,0	5,6 12,5 24,5 43,4 86,7	5,4 11,7 22,1 35,6 61,1	5,1 10,7 20,2 32,4 55,6	4,7 9,9 18,7 30,1 51,9	4,0 8,4 15,8 25,3 43,6	1.27	8.01	0.72-1.27						
CF4 65 G CF4 80 G CF4 105 G CF4 130 G CF4 165 G				210	150	9,5 15,5 31,5 54,0 98,0	7,2 13,5 29,0 51,0 93,8	6,9 12,6 26,1 41,8 66,1	6,5 11,5 24,0 38,1 60,1	6,1 10,7 22,1 35,4 56,2	5,1 9,1 18,7 29,8 47,1	1.27	8.01	0.61-1.09				
CF4 65 G CF4 80 G CF4 105 G CF4 130 G CF4 165 G						270	90	9,5 26,0 45,5 68,5 150,0	7,9 22,5 42,5 65,0 145,0	7,6 21,0 38,3 53,3 102,1	7,2 19,2 35,1 48,5 92,9	6,7 17,9 32,4 45,1 86,8	5,6 15,1 27,4 37,9 72,9	1.4	6.62	0.53-0.93		
CF4 65 G CF4 80 G CF4 105 G CF4 130 G CF4 165 G								300	60	9,5 26,0 52,5 91,5 204,0	8,0 23,6 49,1 87,4 198,5	7,7 22,1 44,2 71,6 139,8	7,3 20,2 40,6 65,2 127,2	6,8 18,7 37,5 60,7 118,9	5,7 15,8 31,7 51,0 99,7	1.4	6.62	0.47-0.84
CF4 65 G CF4 80 G CF4 105 G CF4 130 G CF4 165 G										120	240	7,0 15,5 27,0 54,0 98,0	5,7 12,7 24,5 43,3 86,6	5,5 11,9 22,1 35,5 61,0	5,2 10,9 20,2 32,3 55,5	4,8 10,1 18,7 30,1 51,9	4,1 8,5 15,8 25,3 43,5	1.27
CF4 65 G CF4 80 G CF4 105 G CF4 130 G CF4 165 G	150	210	9,5 20,5 32,5 64,0 101,0	7,3 18,4 30,0 60,5 97,2	7,0 17,2 27,0 49,6 68,5							6,6 15,7 24,8 45,1 62,3	6,2 14,6 22,9 42,0 58,2	5,2 12,3 19,4 35,3 48,8	1.27	8.01	0.57-1.02	
CF4 65 G CF4 80 G CF4 105 G CF4 130 G CF4 165 G			180	180	9,5 26,0 45,5 69,5 152,7	7,8 23,0 42,8 66,0 148,0	7,5 21,5 38,6 54,1 104,2					7,1 19,7 35,4 49,3 94,9	6,6 18,3 32,7 45,8 88,6	5,6 15,4 27,6 38,5 74,4	1.4	6.62	0.53-0.93	
CF4 65 G CF4 80 G CF4 105 G CF4 130 G CF4 165 G					210	150	10,0 26,5 53,0 93,0 208,5	8,5 24,2 50,1 89,2 203,5	8,2 22,6 45,1 73,1 143,3			7,7 20,7 41,4 66,6 130,4	7,2 19,2 38,2 61,9 121,9	6,1 16,2 32,3 52,0 102,3	1.4	6.62	0.45-0.80	
CF4 65 G CF4 80 G CF4 105 G CF4 130 G CF4 165 G							270	90	10,5 31,0 58,0 100,5 228,5	9,1 28,5 55,0 96,5 223,5	8,8 26,6 49,5 79,1 157,4	8,3 24,4 45,5 72,0 143,3	7,7 22,6 42,0 67,0 133,8	6,5 19,1 35,5 56,3 112,3	1.76	5.53	0.44-0.78	



TABLE OF DYNAMIC CAPACITIES

CF4 CODE				Static torque Ms [da Nm]	Dynamic torque (at output) cycle/min					Coeff. of Velocity Cv	Coeff. of Accel. Ca	Coeff. of Transm. kJ-KI
Series	Number of stations S	Angle of displacement B°	Angle of dwell Bp°		50 cycles/1'	100 cycles/1'	150 cycles/1'	200 cycles/1'	300 cycles/1'			
CF4 65 G CF4 80 G CF4 105 G CF4 130 G CF4 165 G	4	90	270	-	-	-	-	-	-	1.27	8.01	0.72-1.27
8,0				6,7	6,3	5,7	5,3	4,5				
12,0				10,3	9,3	8,5	7,9	6,6				
29,0				26,5	21,7	19,8	18,4	15,5				
46,5				43,5	30,6	27,9	26,0	21,9				
CF4 65 G CF4 80 G CF4 105 G CF4 130 G CF4 165 G		120	240	5,5	4,2	4,0	3,8	3,6	3,0	1.27	8.01	0.54-0.95
10,5				9,1	8,5	7,8	7,2	6,1				
21,0				19,2	17,3	15,9	14,7	12,4				
41,0				38,4	31,5	28,7	26,7	22,4				
CF4 65 G CF4 80 G CF4 105 G CF4 130 G CF4 165 G		150	210	8,5	7,1	6,8	6,5	6,0	5,1	1.4	6.62	0.47-0.84
11,5				10,0	9,3	8,5	7,9	6,7				
30,0				27,7	25,0	22,9	21,1	17,9				
47,0				44,2	36,2	33,0	30,7	25,8				
91,0				87,5	61,6	56,1	52,4	44,0				
CF4 65 G CF4 80 G CF4 105 G CF4 130 G CF4 165 G		180	180	8,0	6,7	6,4	6,1	5,7	4,8	1.76	5.53	0.49-0.88
11,0				9,6	9,0	8,2	7,6	6,4				
28,5				26,1	23,5	21,6	19,9	16,8				
44,5				41,8	34,3	31,2	29,0	24,4				
86,0	82,5			58,1	52,9	49,4	41,5					
CF4 65 G CF4 80 G CF4 105 G CF4 130 G CF4 165 G	210	150	8,5	7,3	7,0	6,6	6,2	5,2	1.76	5.53	0.42-0.75	
12,0			10,4	9,7	8,9	8,3	7,0					
34,0			31,7	28,6	26,2	24,2	20,5					
59,0			56,2	46,1	41,9	39,0	32,8					
92,0			88,6	62,4	56,8	53,1	44,5					
CF4 65 G CF4 80 G CF4 105 G CF4 130 G CF4 165 G	270	90	9,5	8,1	7,8	7,4	6,9	5,8	1.76	5.53	0.33-0.58	
19,5			17,5	16,4	15,0	13,9	11,7					
41,5			38,8	35,0	32,1	29,6	25,0					
72,0			68,6	56,2	51,2	47,6	40,0					
129,0			125,2	88,2	80,3	75,0	62,9					
CF4 65 G CF4 80 G CF4 105 G CF4 130 G CF4 165 G	5	90	270	-	-	-	-	-	-	1.76	5.53	0.79-1.41
6,5				5,5	5,0	4,5	4,2	3,5				
14,0				12,2	10,0	9,1	8,5	7,1				
34,5				32,1	22,6	20,6	19,2	16,1				
CF4 65 G CF4 80 G CF4 105 G CF4 130 G CF4 165 G				120	240	6,0	5,0	4,7	4,3			
13,0		11,4	10,3			9,4	8,7	7,4				
24,5		22,5	18,4			16,8	15,6	13,1				
49,0		46,1	32,5			29,6	27,6	23,2				
CF4 65 G CF4 80 G CF4 105 G CF4 130 G CF4 165 G		150	210	10,0	8,4	7,9	7,2	6,7	5,6	1.76	5.53	0,47-0.84
14,5				12,8	11,5	10,6	9,8	8,3				
35,0				32,9	27,0	24,6	22,8	19,2				
57,0				54,1	38,1	34,7	32,4	27,2				
CF4 65 G CF4 80 G CF4 105 G CF4 130 G CF4 165 G				180	180	7,0	5,1	4,9	4,6			
10,5		9,0	8,4			7,7	7,1	6,0				
24,0		22,3	20,1			18,4	17,0	14,4				
43,0		40,7	33,4			30,4	28,3	23,7				
CF4 65 G CF4 80 G CF4 105 G CF4 130 G CF4 165 G		210	150	7,0	5,4	5,2	4,9	4,6	3,9	1.76	5.53	0.34-0.60
14,0				11,2	10,5	9,6	8,9	7,5				
24,5	22,6			20,4	18,7	17,3	14,6					
44,0	41,8			34,3	31,2	29,0	24,4					
85,5	82,2			57,9	52,7	49,2	41,3					
CF4 65 G CF4 80 G CF4 105 G CF4 130 G CF4 165 G	270	90	7,0	5,9	5,7	5,4	5,0	4,2	1.76	5.53	0.26-0.47	
14,0			12,3	11,5	10,5	9,8	8,3					
35,0			32,8	29,5	27,1	25,0	21,2					
52,5			50,1	41,1	37,4	34,8	29,2					
110,0			105,3	74,2	67,5	63,1	52,9					



TABLE OF DYNAMIC CAPACITIES

CF4 CODE				Static torque Ms [da Nm]	Dynamic torque (at output) cycle/min					Coeff. of velocity Cv	Coeff. of Accel. Ca	Coeff. of Transm. kj-KI
Series	Number of stations S	Angle of displacement B°	Angle of dwell Bp°		50 cycles/1'	100 cycles/1'	150 cycles/1'	200 cycles/1'	300 cycles/1'			
CF4 65 G CF4 80 G CF4 105 G CF4 130 G CF4 165 G	6	90	270	7,0	5,4	5,2	4,9	4,6	3,9	1.76	5.53	0.66-1.17
14,0				12,1	11,3	10,3	9,6	8,1				
26,0				23,6	21,3	19,5	18,0	15,2				
45,0				42,0	34,4	31,3	29,2	24,5				
69,5				65,8	46,3	42,2	39,4	33,1				
CF4 65 G CF4 80 G CF4 105 G CF4 130 G CF4 165 G		120	240	11,0	7,1	6,8	6,5	6,0	5,1	1.76	5.53	0.49-0.88
20,5				18,2	17,0	15,6	14,4	12,2				
34,0				31,2	28,1	25,8	23,8	20,1				
64,5				61,0	50,0	45,5	42,4	35,6				
102,0				98,2	69,2	62,9	58,8	49,3				
CF4 65 G CF4 80 G CF4 105 G CF4 130 G CF4 165 G		150	210	11,0	8,0	7,7	7,3	6,8	5,7	1.76	5.53	0.40-0.70
25,5				23,1	21,6	19,7	18,3	15,5				
47,0	44,0			39,6	36,4	33,6	28,4					
71,5	67,8			55,6	50,6	47,1	39,6					
157,0	152,4			107,3	97,7	91,3	76,6					
CF4 65 G CF4 80 G CF4 105 G CF4 130 G CF4 165 G	180	180	11,0	8,6	8,3	7,8	7,3	6,1	1.76	5.53	0.33-0.59	
31,0			26,9	25,1	23,0	21,3	18,1					
62,0			52,0	46,8	43,0	39,7	33,5					
106,0			91,8	75,2	68,5	63,8	53,6					
245,0			211,2	148,7	135,4	126,5	106,1					
CF4 65 G CF4 80 G CF4 105 G CF4 130 G CF4 165 G	210	150	11,0	9,0	8,7	8,2	7,6	6,4	1.76	5.53	0.28-0.50	
31,0			28,2	26,4	24,1	22,4	18,9					
62,0			55,3	49,8	45,7	42,2	35,7					
106,0			96,5	79,1	72,0	67,0	56,3					
245,0			223,9	157,7	143,5	134,1	112,5					
CF4 65 G CF4 80 G CF4 105 G CF4 130 G CF4 165 G	270	90	11,0	9,6	9,2	8,7	7,1	6,9	1.76	5.53	0.22-0.39	
33,5			30,9	28,9	26,4	24,5	20,7					
62,0			58,9	53,1	48,7	45,0	38,0					
106,0			102,0	83,6	76,1	70,8	59,5					
245,0			239,7	168,8	153,7	143,5	120,5					
CF4 65 G CF4 80 G CF4 105 G CF4 130 G CF4 165 G	8	90	270	5,5	4,0	3,8	3,6	3,4	2,9	1.76	5.53	0.49-0.88
10,5				8,8	8,2	7,5	7,0	5,9				
20,6				18,7	16,8	15,5	14,3	12,1				
39,5				36,9	30,2	27,5	25,6	21,5				
70,5				67,0	47,2	42,9	40,1	33,7				
CF4 65 G CF4 80 G CF4 105 G CF4 130 G CF4 165 G		120	240	11,0	7,0	6,7	6,4	5,9	5,0	1.76	5.53	0.37-0.66
11,5				9,8	9,2	8,4	7,8	6,6				
34,0				31,5	28,4	26,0	24,0	20,3				
59,5				56,6	46,4	42,2	39,3	33,0				
92,0				88,7	62,5	56,9	53,1	44,6				
CF4 65 G CF4 80 G CF4 105 G CF4 130 G CF4 165 G		150	210	11,0	7,5	7,2	6,8	6,4	5,4	1.76	5.53	0.29-0.53
20,5				16,9	15,8	14,4	13,4	11,3				
40,5	38,1			34,3	31,5	29,1	24,6					
71,0	67,5			55,3	50,4	46,9	39,4					
137,0	124,0			87,3	79,5	74,3	62,3					
CF4 65 G CF4 80 G CF4 105 G CF4 130 G CF4 165 G	180	180	11,0	8,4	8,1	7,6	7,1	6,0	1.76	5.53	0.25-0.44	
20,5			17,8	16,6	15,2	14,1	11,9					
51,0			42,8	38,6	35,4	32,7	27,6					
95,0			82,6	67,7	61,6	57,4	48,2					
137,0			132,9	93,6	85,2	79,6	66,8					
CF4 65 G CF4 80 G CF4 105 G CF4 130 G CF4 165 G	210	150	11,0	8,9	8,6	8,1	7,5	6,4	1.76	5.53	0.21-0.38	
20,5			18,6	17,4	15,9	14,8	12,5					
51,0			45,2	40,7	37,4	34,5	29,2					
95,0			86,5	70,9	64,6	60,1	50,5					
199,5			188,9	133,0	121,1	113,1	94,9					
CF4 65 G CF4 80 G CF4 105 G CF4 130 G CF4 165 G	270	90	11,0	9,5	9,1	8,6	8,1	6,8	1.76	5.53	0.17-0.29	
20,5			18,5	17,3	15,8	14,7	12,4					
51,0			48,1	43,3	39,8	36,7	31,0					
95,0			91,4	74,9	68,2	63,5	53,3					
199,5			195,0	137,3	125,0	116,8	98,0					



TABLE OF DYNAMIC CAPACITIES

CF4 CODE				Static torque Ms [da Nm]	Dynamic torque (at output) cycle/min					Coeff. of velocity Cv	Coeff. of Accel. Ca	Coeff. of Transm. kj-KI	
Series	Number of stations S	Angle of displacement B°	Angle of dwell Bp°		50 cycles/1'	100 cycles/1'	150 cycles/1'	200 cycles/1'	300 cycles/1'				
CF4 65 G CF4 80 G CF4 105 G CF4 130 G CF4 165 G	10	90	270	-	-	-	-	-	-	1.76	5.53	0.40-0.70	
10,0				8,5	7,9	7,3	6,7	5,7					
15,0				12,9	11,6	10,7	9,8	8,3					
36,5				33,7	27,6	25,1	23,4	19,7					
81,5				69,1	48,7	44,3	41,4	34,7					
CF4 65 G CF4 80 G CF4 105 G CF4 130 G CF4 165 G		120	240	240	11,0	5,4	5,2	4,9	4,6	3,9	1.76	5.53	0.30-0.53
16,0					11,2	10,5	9,6	8,9	7,5				
25,5					23,4	21,1	19,3	17,9	15,1				
50,0					47,2	38,7	35,2	32,8	27,5				
81,5					78,3	55,1	50,2	46,9	39,3				
CF4 65 G CF4 80 G CF4 105 G CF4 130 G CF4 165 G		150	210	210	12,0	8,7	8,4	7,9	7,4	6,2	1.76	5.53	0.24-0.42
16,0					12,4	11,6	10,6	9,8	8,3				
37,0					33,7	30,4	27,9	25,7	21,7				
57,0					54,0	44,3	40,3	37,5	31,5				
112,0					107,2	75,5	68,7	64,2	53,9				
CF4 65 G CF4 80 G CF4 105 G CF4 130 G CF4 165 G		180	180	180	12,0	9,3	8,9	8,5	7,9	6,6	1.76	5.53	0.2 -0.35
16,0					13,0	12,1	11,1	10,3	8,7				
46,5					40,3	36,3	33,3	30,8	26,0				
75,5	72,1				59,1	53,8	50,1	42,1					
161,0	144,3				101,6	92,5	86,4	72,5					
CF4 65 G CF4 80 G CF4 105 G CF4 130 G CF4 165 G	210	150	150	12,0	9,7	9,3	8,8	8,2	6,9	1.76	5.53	0.17-0.30	
16,0				13,7	12,8	11,7	10,9	9,2					
46,5				41,8	37,7	34,5	31,9	27,0					
90,0				82,3	67,5	61,4	57,2	48,0					
161,0				150,8	106,2	96,7	90,3	75,8					
CF4 65 G CF4 80 G CF4 105 G CF4 130 G CF4 165 G	270	90	90	12,0	10,5	10,1	9,5	8,9	7,5	1.76	5.53	0.13-0.23	
16,0				14,5	13,6	12,4	11,5	9,7					
46,5				43,8	39,5	36,2	33,4	28,3					
90,0				86,5	70,9	64,6	60,1	50,5					
161,0				157,0	110,6	100,6	94,0	78,9					
CF4 65 G CF4 80 G CF4 105 G CF4 130 G CF4 165 G	12	90	270	-	-	-	-	-	-	1.76	5.53	0.33-0.59	
8,5				6,5	6,1	5,6	5,2	4,4					
15,5				14,0	12,6	11,6	10,7	9,0					
30,0				28,2	23,1	21,0	19,6	16,5					
60,5				57,8	40,7	37,1	34,6	29,0					
CF4 65 G CF4 80 G CF4 105 G CF4 130 G CF4 165 G		120	240	240	8,5	5,9	5,7	5,4	5,0	4,2	1.76	5.53	0.25-0.44
12,0					10,4	9,7	8,9	8,3	7,0				
17,5					16,0	14,4	13,2	12,2	10,3				
43,5					41,2	33,8	30,7	28,6	24,0				
87,5					84,7	59,6	54,3	50,7	42,6				
CF4 65 G CF4 80 G CF4 105 G CF4 130 G CF4 165 G		150	210	210	8,5	6,5	6,3	5,9	5,5	4,6	1.76	5.53	0.2 -0.35
16,5					13,0	12,1	11,1	10,3	8,7				
32,0					27,3	24,6	22,6	20,8	17,6				
53,5					50,8	41,6	37,9	35,3	29,6				
103,0					100,0	70,4	64,1	59,9	50,3				
CF4 65 G CF4 80 G CF4 105 G CF4 130 G CF4 165 G		180	180	180	8,5	6,8	6,5	6,2	5,8	4,9	1.76	5.53	0.16-0.29
16,5					13,5	12,6	11,5	10,7	9,1				
32,0					28,4	25,6	23,5	21,7	18,3				
62,0	59,1				48,4	44,1	41,0	34,5					
138,5	121,7				85,7	78,0	72,9	61,2					
CF4 65 G CF4 80 G CF4 105 G CF4 130 G CF4 165 G	210	150	150	8,5	7,2	6,9	6,5	6,1	5,1	1.76	5.53	0.14-0.25	
16,5				14,5	13,6	12,4	11,5	9,7					
32,0				29,1	26,2	24,0	22,2	18,8					
71,0				64,6	53,0	48,2	44,9	37,7					
138,5				128,0	90,1	82,1	76,6	64,3					
CF4 65 G CF4 80 G CF4 105 G CF4 130 G CF4 165 G	270	90	90	8,5	7,5	7,2	6,8	6,4	5,4	1.76	5.53	0.11-0.20	
16,5				14,5	13,6	12,4	11,5	9,7					
32,0				30,0	27,0	24,8	23,0	19,4					
71,0				68,0	55,7	50,7	47,2	39,7					
138,5				135,0	95,1	86,5	80,8	67,8					



TABLE OF DYNAMIC CAPACITIES

CF4 CODE				Static torque Ms [da Nm]	Dynamic torque (at output) cycle/min					Coeff. of velocity Cv	Coeff. of Accel. Ca	Coeff. of Transm. kj-KI	
Series	Number of stations S	Angle of displacement B°	Angle of dwell Bp°		50 cycles/1'	100 cycles/1'	150 cycles/1'	200 cycles/1'	300 cycles/1'				
CF4 65 G CF4 80 G CF4 105 G CF4 130 G CF4 165 G	16*	90	270	-	-	-	-	-	-	1.76	5.53	0.49-0.88	
9,5				8,0	7,5	6,8	6,3	5,4					
19,5				18,1	16,3	15,0	13,8	11,7					
38,5				37,0	30,3	27,6	25,7	21,6					
66,5				64,5	45,4	41,3	38,6	32,4					
CF4 65 G CF4 80 G CF4 105 G CF4 130 G CF4 165 G		120	240	-	-	-	-	-	-	-	1.76	5.53	0.37-0.66
18,5				17,5	16,4	15,0	13,9	11,7					
35,0				33,5	30,2	27,7	25,6	21,6					
58,5				56,5	46,3	42,2	39,2	33,0					
140,0				137,3	96,8	88,1	82,3	69,1					
CF4 65 G CF4 80 G CF4 105 G CF4 130 G CF4 165 G		150	210	-	-	-	-	-	-	-	1.76	5.53	0.29-0.53
18,5				17,2	16,1	14,7	13,7	11,5					
35,0				32,9	29,6	27,2	25,1	21,2					
58,0				54,4	44,6	40,6	37,8	31,7					
140,0				137,3	96,7	88,0	82,2	69,0					
CF4 65 G CF4 80 G CF4 105 G CF4 130 G CF4 165 G		180	180	-	-	-	-	-	-	-	1.76	5.53	0.25-0.44
18,5	16,2			15,1	13,8	12,9	10,9						
35,0	31,7			28,6	26,2	24,2	20,5						
58,0	52,5			43,0	39,2	36,5	30,6						
140,0	134,0			94,4	85,9	80,2	67,3						
CF4 65 G CF4 80 G CF4 105 G CF4 130 G CF4 165 G	210	150	-	-	-	-	-	-	-	1.76	5.53	0.21-0.38	
18,5			16,5	15,4	14,1	13,1	11,1						
35,0			30,7	27,7	25,4	23,4	19,8						
58,0			50,9	41,7	38,0	35,3	29,7						
140,0			132,0	93,0	84,6	79,0	66,3						
CF4 65 G CF4 80 G CF4 105 G CF4 130 G CF4 165 G	270	90	-	-	-	-	-	-	-	1.76	5.53	0.17-0.29	
9,0			7,8	7,5	7,1	6,6	5,6						
18,5			15,6	14,6	13,3	12,4	10,5						
35,0			29,5	26,6	24,4	22,5	19,0						
58,0			53,6	43,9	40,0	37,2	31,3						
140,0	125,2	88,2	80,3	75,0	62,9								
CF4 65 G CF4 80 G CF4 105 G CF4 130 G CF4 165 G	20*	90	270	-	-	-	-	-	-	1.76	5.53	0.40-0.70	
20,4				19,2	17,3	15,9	14,7	12,4					
39,6				38,0	31,1	28,4	26,4	22,2					
75,8				73,9	52,0	47,4	44,3	37,1					
CF4 65 G CF4 80 G CF4 105 G CF4 130 G CF4 165 G		120	240	-	-	-	-	-	-	-	1.76	5.53	0.30-0.53
20,0				18,7	16,8	15,5	14,3	12,1					
38,0				36,5	29,9	27,2	25,3	21,3					
107,0				105,0	73,9	67,3	62,9	52,8					
CF4 65 G CF4 80 G CF4 105 G CF4 130 G CF4 165 G		150	210	-	-	-	-	-	-	-	1.76	5.53	0.24-0.42
20,0				17,9	16,1	14,8	13,7	11,5					
38,0				35,0	28,7	26,1	24,3	20,4					
107,0				101,0	71,1	64,7	60,5	50,8					
CF4 65 G CF4 80 G CF4 105 G CF4 130 G CF4 165 G		180	180	-	-	-	-	-	-	-	1.76	5.53	0.2 -0.35
11,5				10,3	9,6	8,8	8,2	6,9					
20,0				17,5	15,8	14,5	13,4	11,3					
38,0				33,7	27,6	25,1	23,4	19,7					
107,0	96,6	68,0	61,9	57,8	48,5								
CF4 65 G CF4 80 G CF4 105 G CF4 130 G CF4 165 G	210	150	-	-	-	-	-	-	-	1.76	5.53	0.17-0.30	
12,0			10,8	10,1	9,2	8,6	7,2						
20,0			16,9	15,2	14,0	12,9	10,9						
38,0			33,0	27,0	24,6	22,9	19,3						
107,0	93,8	66,1	60,1	56,2	47,1								
CF4 65 G CF4 80 G CF4 105 G CF4 130 G CF4 165 G	270	90	-	-	-	-	-	-	-	1.76	5.53	0.13-0.23	
12,0			10,7	10,0	9,1	8,5	7,2						
20,0			16,5	14,9	13,6	12,6	10,6						
38,0			32,3	26,5	24,1	22,4	18,8						
107,0	90,5	63,7	58,0	54,2	45,5								

TABLE OF DYNAMIC CAPACITIES

CF4 CODE				Static torque Ms [da Nm]	Dynamic torque (at output) cycle/min					Coeff. of velocity Cv	Coeff. of Accel. Ca	Coeff. of Transm. kj-KI
Series	Number of stations S	Angle of displacement B°	Angle of dwell Bp°		50 cycles/1'	100 cycles/1'	150 cycles/1'	200 cycles/1'	300 cycles/1'			
CF4 65 G CF4 80 G CF4 105 G CF4 130 G CF4 165 G	24*	90	270	-	-	-	-	-	-	1.76	5.53	0.33-0.59
14,5				13,3	12,0	11,0	10,2	8,6				
22,0				20,8	17,0	15,5	14,4	12,1				
73,0				71,4	50,3	45,8	42,8	35,9				
-				-	-	-	-	-				
CF4 65 G CF4 80 G CF4 105 G CF4 130 G CF4 165 G		120	240	-	-	-	-	-	-	1.76	5.53	0.25-0.44
14,5				12,6	11,4	10,4	9,6	8,1				
22,0				19,5	16,0	14,6	13,5	11,4				
73,0				68,8	48,5	44,1	41,2	34,6				
-				-	-	-	-	-				
CF4 65 G CF4 80 G CF4 105 G CF4 130 G CF4 165 G		150	210	-	-	-	-	-	-	1.76	5.53	0.2 -0.35
19,0				17,8	16,0	14,7	13,6	11,5				
25,0				22,6	18,5	16,9	15,7	13,2				
73,0				65,5	46,1	42,0	39,2	32,9				
-				-	-	-	-	-				
CF4 65 G CF4 80 G CF4 105 G CF4 130 G CF4 165 G		180	180	-	-	-	-	-	-	1.76	5.53	0.16-0.29
19,0				17,3	15,6	14,3	13,2	11,2				
25,0				22,1	18,1	16,5	15,3	12,9				
73,0				63,3	44,6	40,6	37,9	31,8				
-				-	-	-	-	-				
CF4 65 G CF4 80 G CF4 105 G CF4 130 G CF4 165 G		210	150	-	-	-	-	-	-	1.76	5.53	0.14-0.25
19,0				16,9	15,2	14,0	12,9	10,9				
25,0				21,8	17,9	16,3	15,1	12,7				
73,0				61,9	43,6	39,7	37,1	31,1				
-	-			-	-	-	-					
CF4 65 G CF4 80 G CF4 105 G CF4 130 G CF4 165 G	270	90	-	-	-	-	-	-	1.76	5.53	0.11-0.20	
19,0			16,5	14,9	13,6	12,6	10,6					
25,0			21,5	17,6	16,0	14,9	12,5					
73,0			60,4	42,5	38,7	36,2	30,4					
-			-	-	-	-	-					

OTHER SPECIAL MOTION CAN BE SUPPLIED ON REQUEST.

The CF4 indexers denoted by (*), with a complete rotation of the input shaft produce two complete cycles of the output shaft: "displacement-dwell , displacement-dwell".



AGENTS

italian

COLOMBO FILIPPETTI Torino S.r.l.

Via Massimo D'Antona,65
I-10040 RIVALTA DI TORINO (TO)
Tel. +39 011 3972211
Fax +39 011 3497863
E-mail: info@cofilto.it
<http://www.cofilto.it>

RDB RIZZARDI S.r.l.

Via Massimo D'Antona,65 - Fraz. Pasta
I-10040 RIVALTA DI TORINO (TO)
Tel. +39 011 3989546
Fax +39 011 3497863
E-mail: rdb@cofil.it
E-mail: rdb.rizzardi@gmail.com

TECNOCAMME

Via Panigale,11
I-40132 Bologna
Tel. +39 051 6415568
Fax +39 051 6419072
E-mail: tecnocamme@cofil.it

MOTION TECH SRL

P.zza S.Giovanni Battista,15-1
I-35035 LISSARO di MESTRINO PD
Tel. +39 049 9004214
Fax +39 049 9004214
E-mail: motion.tech@cofil.it

WIDE AUTOMATION SRL

Via Malpasso,1340
I-47842 S.GIOVANNI IN MARIGNANO RN
Tel. +39 0541 827200
Fax +39 0541 825021
E-mail: info@wideautomation.it
<http://www.wideautomation.it>

CM ENGINEERING

Via Della Pineta,34
I-65129 PESCARA PE
Tel. +39 085 7998879
Tel. +39 333 1035570
Fax +39 1782766858
E-mail: cmengineering@cofil.it
<http://www.cmengineering.it>

AGENZIA RDS

Zona ind.le localita' Pozzobianco
I-81025 MARCIANISE CE
mobile +39 0823 451233
Fax +39 0823 1780114
mobile +39 335 1289960
E-mail: raffaele.desimone@agenziards.com
<http://www.agenziards.com>

european

COLOMBO FILIPPETTI SPA

SUCCURSALE FRANCE
France
Bp 14-2 Rue de Bâle
F-68180 HORBOURG WIHR CEDEX
Tel. +33 3 89216867
Fax +33 3 89216999
E-mail: cofil@cofil.fr
<http://www.cofil.fr>

MIKSCH GMBH

Germany
Reutlinger Strasse 5
D-73037 GÖPPINGEN
Tel. +49 7161 67240
Fax +49 7161 6724-97
E-mail: mikschi@mikschi.de
<http://www.mikschi.de>

PRECISION MOTION (COFIL) LTD

Great Britain
PO Box 2034
Preston - Lancashire
PR5 9AD
Tel. +44 (0)1772 339633
Fax. +44 (0)1772 336362
Email : stuart@precisionmotion.co.uk
<http://www.precisionmotion.co.uk>

CUBY

TRANSMISION DE POTENCIA S.L.
Spain
C/Permanyer,34
E-08205 SABADELL Barcellona
Tel. +34 93 7451950
Fax +34 93 7255079
E-mail: info@cuby.es
<http://www.cuby.es>



overseas

GEAREX CORPORATION

Taiwan
NO.13, TA TUNG 1ST RD.,
KUAN YIN IND,PARK,
TAOYUAN HSIEN TAIPEI
Tel. +886 26322856
Fax +886 34831427
E-mail: trans888@ms27.hinet.net
<http://www.gearex.com.tw>

INDEXING TECHNOLOGIES INC.

U.S.A
P.O. BOX 252,37 Orchard St.
RAMSEY, N.J. 07446-0252
Tel. +1 201 9346333
Fax +1 201 9346488
E-mail: info@indexingtechnologies.com
<http://www.indexingtechnologies.com>

PRECISION INTERNATIONAL

India
108,Aashirwad,Green Park (Main)
NEW DELHI-110016
Tel. +91 11 26561687
Fax +91 11 26851390
E-mail: precinter@vsnl.com
<http://www.precinter.com>